

**TECHNICAL SPECIFICATION
PROCUREMENT GUARD COUNTER/RECEPTION DESK
FOR OFFICIAL USE OF THE OFFICE OF THE SECRETARY**

I. PROJECT

Procurement of Guard Counter/ Reception Desk for the official use of the Office of the Secretary.

II. MINIMUM REQUIREMENTS

1. Supplier must have at least three (3) years of experience in producing and supplying the items to ensure reliability and product quality assurance.
2. Supplier must be willing to transact on a send bill arrangement.
3. The ABC shall cover the delivery charges, VAT and other related expenses and applicable government taxes.

III. SPECIFICATIONS

Guard Counter/Reception Desk Two (2) pcs

Material : Use $\frac{3}{4}$ Marine Plywood Laminate with Formica Laminate using the Walnut Butcher Block Laminate (See attached picture)
Finish : Matte/Natural grain

Size : Length .80 MTS x Width .60 MTS

Height : 1.10 MTS

LOVE THE PHILIPPINES LOGO/BRANDING
Love the Philippines Branding Logo
Letters only in Cut out Acrylic (No White Background)
2 cm Thickness
Size proportion to area 60 cm x 30 cm

V. DELIVERY PERIOD

Delivery and installation is Five (5) working days upon receipt of the approved funded purchase order.

Address: Department of Tourism Building
351 Sen. Gil Puyat Avenue., Makati City.

VI. TERMS OF PAYMENT

Payment shall be made via send bill arrangements based on the actual items delivered not to exceed the total estimated budget.

VII. BUDGET ESTIMATE

The total budget estimate **SIXTY FOUR THOUSAND TWO HUNDRED THIRTY SEVEN PESOS 20/100 (Php 64,237.20)**, inclusive of all cost for delivery, VAT and other applicable taxes, chargeable against to Osec Funds FY 2024.

VIII. PROJECT OFFICER / CONTACT PERSON

NENITA M. SALUDO

Executive Assistant IV

Office of the Secretary (OSEC)

Cp and Viber no.: 09778038419

Email: nmsaludo@tourism.gov.ph

APPROVED BY:



ATTY. GLENN ALBERT M. OCAMPO

Head Executive Assistant

Office of the Secretary

MATERIALS SPECIFICATION FOR GUARD COUNTER

- Materials specifications:
 - Used ¾ Marine Plywood laminate with Formica Laminate using the Walnut Butcherblock laminate (See attached picture below)
 - Size: LENGTH .80 MTS X WITDH .60 MTS X HEIGHT 1.10 MTS (See attached drawings)
- Love the Philippines logo/Branding
 - Love the Philippines Branding logo letters only in Cut out Acrylic (No white Background) 2 cm thickness
 - Size proportion to area 60cmx 30cm

Rumaisa



Brand: Formica Laminate
Code: Walnut Butcherblock
Finish: Matte / Natural Grain



COUNTER DIMENSION

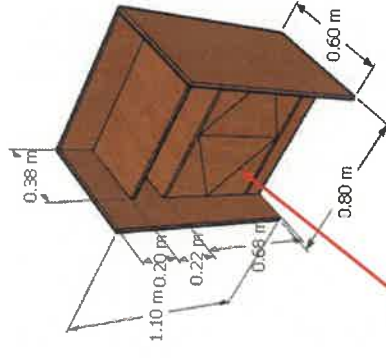
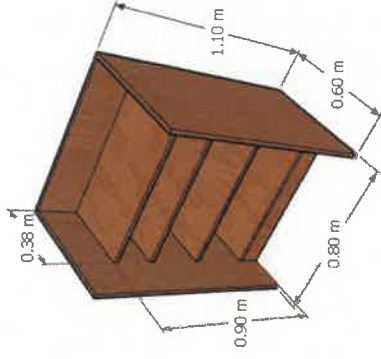

WITH TWO SWING OUT DOOR

