

TERMS OF REFERENCE

I. NAME OF PROJECT: Booth Design, Set-up and Dismantling of the DOT MIMAROPA Booth for the 35th Philippine Travel Mart (PTM) 2024 at SMX Convention Center, Mall of Asia

II. IMPLEMENTATION: September 06 - 08, 2024

III. MINIMUM REQUIREMENTS:

1. Must have experience working on travel and trade fairs and/or other similar events.
2. Must be able to provide samples of previous work.
3. Must be able to provide services on a Send-Bill Arrangement.
4. Must have PhilGEPS Registration

IV. PAVILION OVERVIEW:

The MIMAROPA Pavilion will showcase different products such as mats, marble products, local fabrics, food items, among others. Likewise, the pavilion will also house five (5) tour operators who can sell their packages and network with other visitors. The pavilion's inspiration is modern and interactive museums in the country which are rooted and inspired in the products to be sold.

V. SCOPE OF WORK/DELIVERABLES:

BOOTH CONSTRUCTION AND DESIGN

- Facilitate permits and attend meetings regarding the 35th Philippine Travel Mart (PTM) 2024.
- Facilitate Ingress and Egress proceedings, as well as forms and permits needed to conduct smooth installation of the booth.
- Subcontractor is required to settle the Subcontractor's Fee of Php 250.00 + 12% VAT per sqm with MSD Godspeed Exhibits Corporation prior to ingress.
- Maintenance of the booth for the duration of the event.
- Provision of personnel who could handle and troubleshoot problems in the booth.
- Design and construction of the DOT MIMAROPA booth, with details and inclusions, to wit: and
 - Develop a creative and engaging booth design that aligns with the theme "Love the NextGen Tourism" and incorporate modern and sustainable design elements to reflect the future-oriented theme while ensuring the design promotes the importance of biodiversity, cultural heritage, and innovative tourism practices. Take note of the four pillars of the mentioned event theme: Sustainability, Digitalization, Inclusivity, and Health & Wellness;
 - Create detailed 3D renderings and layout plans for the booth including designated areas for interactive displays, product showcases, informational kiosks, and visitor engagement zones and design spaces for technological integrations (TV)

- All design and landscaping materials and procedures for 54 sqm. (9x6) Booth.
- Construct the booth using eco-friendly materials.
- Assemble all display elements, including screens, stands, and promotional materials.
- Free flowing coffee and water dispenser with coffee and water supply for three (3) days.
- 3 Painter Canvass (16/20), Easel Stand, Acrylic Paint set, and Paint Brushes.
- All labor-related expenses.
- All other expenses necessary for the construction of the booth.
- Storage space.
- Rent of 7 pcs. Nordic bar stool (w/ backrest) and 5 pcs. – 97cm height single bar table
- Rent of additional seat/long bench for 7 sellers
- Rent of Lounge Area Sofa
- Rent of 1 pc. - 97 cm height two-person bar table
- Rent of 6 brochure racks
- Rent of 65 inches LED TV
- Rent of Fabric Display of minimum 2 spiral soft-fabric rack and 6 weaved material (*banig*) rack
- Rent of Art Display Case / Hanger for 10 pcs. varying size canvas
- Minimum of 6 Display Cases / Container for Food Product Display
- 3 wide open item case for Marble Products, Beaded Products, and other non-edible products
- Rent of 1 garment display rack + 16 clothes hanger

VI. BUDGET

The total budget allocation is **TWO HUNDRED EIGHTY-FIVE THOUSAND PESOS ONLY (₱285,000.00)**, inclusive of taxes and fees.

VI. DOCUMENTARY REQUIREMENTS

1. Mayor's Permit
2. PhilGEPS Certification (Preferably Platinum Member)
3. Notarized Omnibus Sworn Statement
4. Proposed Design for the Booth
5. Portfolio of previous work experience (e.g. photos, certificates, etc.)

The winning bid shall be determined based on the proposal with the most advantageous financial package cost, provided that the amount of the bid does not exceed the above total budget.

Contact Person: **Mr. Reynaldo P. Gabriel Jr.**
 DOT MIMAROPA Regional Office
 Mobile (0916) 469-3632
dot4b.bacsecretariat@gmail.com

Sample bar table (size in cm):

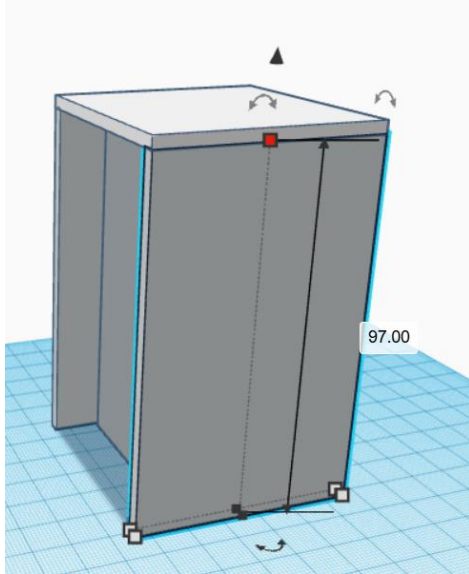

Front

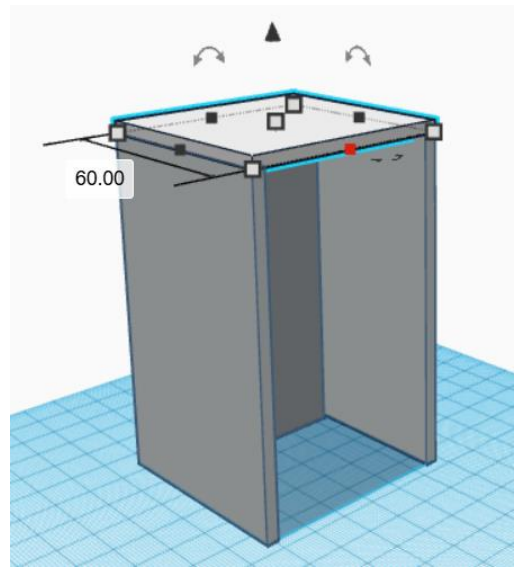

Back

Sample bar stool (height 65cm / relative to height of bar table):



Sample Fabric Hanger



Sample Garments Rack and Fashion items display

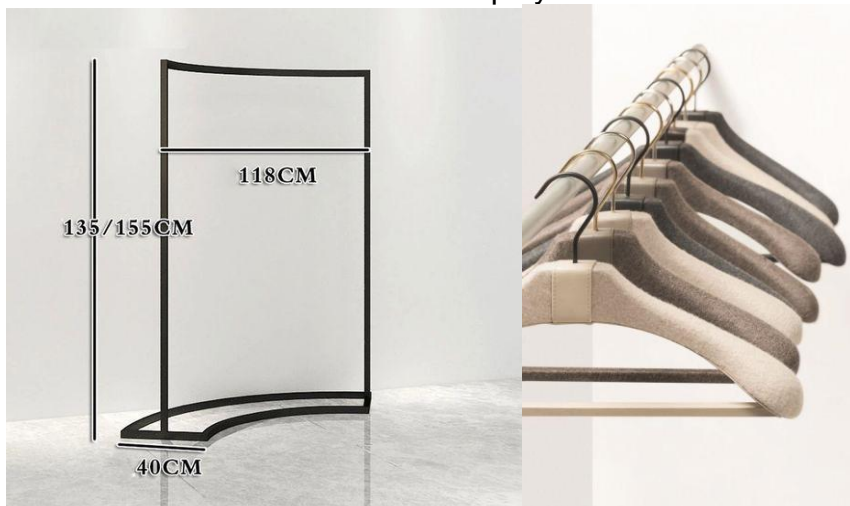

Sample Art Display



Sample Item Display (Food)



Sample Item Display (Non-edible Products) *open case for interaction



Sample Interactive Display

